

Microturbine Technology & Business Developments

Presented at
World Energy Engineering Congress 2000
Atlanta, Georgia
October 26, 2000

N. Richard Friedman, Chairman
Resource Dynamics Corporation

World Energy Engineering Congress 2000

The Energy Market is Changing

- Industry Restructuring Transforming Delivery of Power & Energy Services
- Distributed Power Generation Technologies Receiving New Attention
 - offer performance and flexibility
 - ideal resources to help address regulatory, environmental and competitive challenges

Distributed Generation Technologies

Generally, non-renewable DG falls in the range of 30kW to 15MW, varying by technology

Technology	Size Range
Microturbines	30-200 kW
Miniturbines	200-1000 kW
Small Turbines	1000-15,000 kW
Reciprocating Engines	30-15,000+ kW
Fuel Cells	30-1000 kW
Fuel Cell Hybrids	200-1000+ kW

World Energy Engineering Congress 2000

What Is A Microturbine?

- Basic Components - Compressor, Combustor, Turbine & Generator
- Single stage radial flow compressor and turbine
- High speed permanent magnet generator - speeds up to 120,000 rpm
- Inverter for 50/60 Hz power
- Recuperator
- Typically 30 kW to 200 kW in Size

World Energy Engineering Congress 2000

What Is A Microturbine?

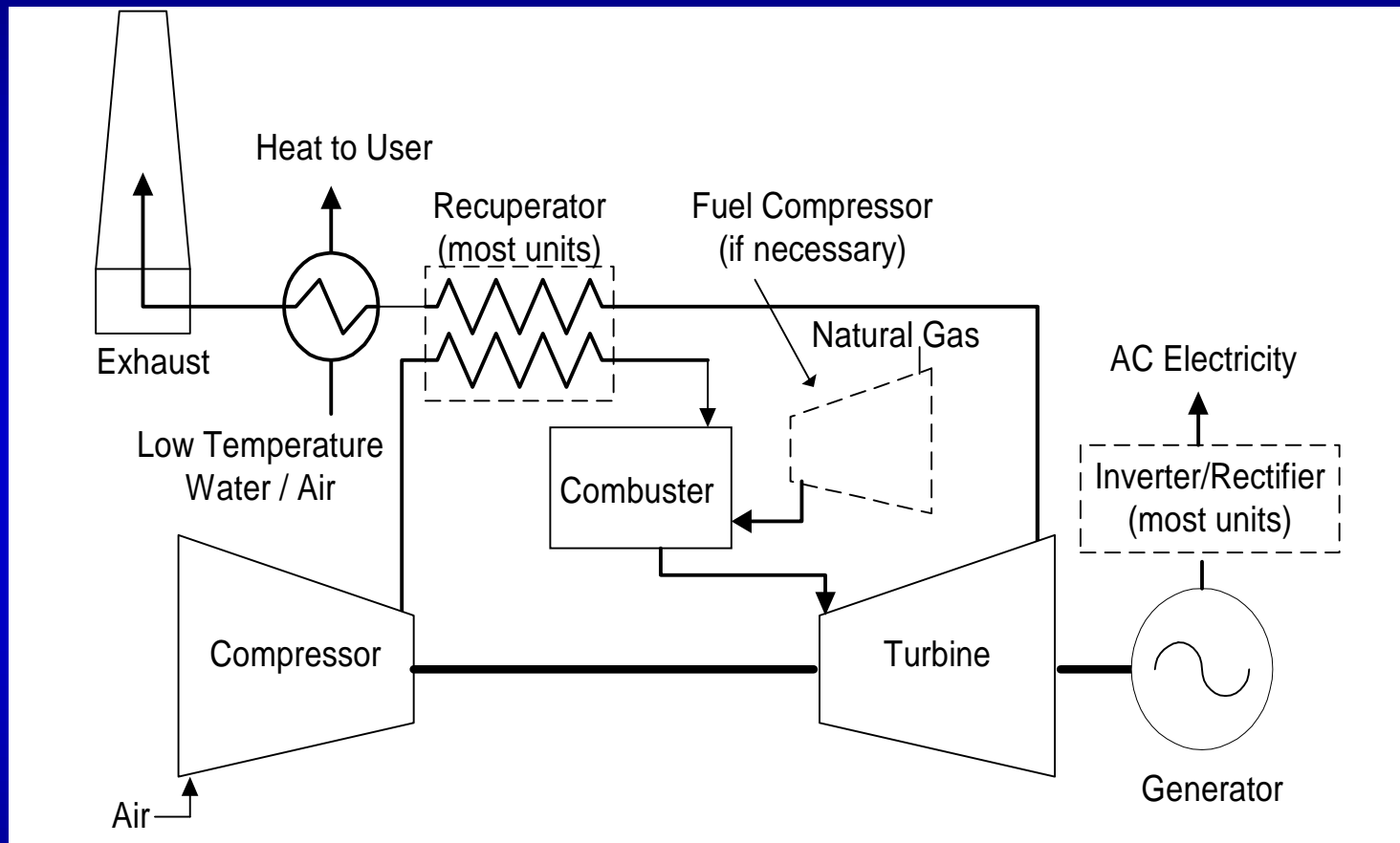

World Energy Engineering Congress 2000

What is the State of Microturbine Technology Today?

- Reliability and Performance Not Quite Realized
- Products are Commercially Available on Limited Basis
- Promised “Production” Cost Levels Not Yet Available

Who Are the Manufacturers?

- Honeywell
- Capstone
- Northern Research & Engineering Corporation
- Elliott Energy/GE Power Systems
- Others

Key Design/Technology Issues

- Recuperator Technology
- Bearing Type
- Inverter
- Single Shaft vs. Dual Shaft
- Package Footprint and Size
- Turbine Inlet Temperature
- Fuel Flexibility

What Benefits Are Promised?

- Low Cost
- Efficiency Levels of Approximately 30%
- High Reliability
- Ease of Maintenance
- Relatively Low Emissions
- Short Lead Time & Siting Close to Load
- Recuperation and Cogeneration Options

Can These Promises Be Kept?

World Energy Engineering Congress 2000

Promise # 1: Low Cost

- Cost goals \$250 to \$500/kW
- Costs may be approaching these goals, but have a way to go
- Current cost data not available
- At least one manufacturer suggest that production price estimates are “crazy”

Promise # 2: 30% Efficiency

- Efficiency Goal Typically Based on Recuperative Design
- Currently Operating Units Either “Prototype” or “Test” Units, But Experience is Increasing Quickly
- Unconfirmed Field Feedback Reports Efficiency Levels of 15%-20%

World Energy Engineering Congress 2000

Promise # 3: High Reliability

- Reliability Data Hard to Collect
- Some Potential Users Planning on Multiple Units for Increased Reliability
- Summer Emergencies Leading to Questions of Ultimate Grid Reliability and Price

World Energy Engineering Congress 2000

Promise # 4: Ease of Maintenance

- Maintenance Requirements Appear to Be Minimal
- Projecting 6,000 to 12,000 Hours Between Scheduled Maintenance
- “Building Engineer” Expertise May Not Be Sufficient
- Still Will Require At Least Experience of Good Auto Mechanic

World Energy Engineering Congress 2000

Promise # 5: Relatively Low Emissions

- General Consensus Seems to Be That Emissions Are Lower Than For Reciprocating Engines
- Sample Emissions Reports From Manufacturers
 - 25 ppm NO_x (75 kW, recuperated)
 - 9 ppm NO_x, 145 ppm CO (45 kW, recuperated)

World Energy Engineering Congress 2000

Promise # 6: Short Lead Time

- 1 - 12 Week Lead Time Indicated
- Set Up in Matter of Hours
- Fairly Mobile
 - Carry in Trunk of Car - 30 kW Unit
(3 ft cube, weigh 250 pounds)
 - Pick Up Truck - 200 kW Unit
(4 ft cube, weigh 450 pounds)

Promise # 7: Recuperation & Cogeneration Options

- Recuperation Mandated for Higher Efficiencies
- Recent RDC Study Identified 12,000 Applications Nationwide
 - Nearly 96% Cogeneration Opportunities
 - Evenly Distributed in 30 kW to 100 kW Size Range
 - Office, Mercantile/Service and Education Sectors Show Highest Potential

World Energy Engineering Congress 2000

Microturbine Applications

- Baseload Power
- Cogeneration
- Peak Shaving
- Premium Power
- Remote Power
- Shaft Drive

World Energy Engineering Congress 2000

Technology Challenges Need to be Addressed

- Ultimate Reliability of Equipment Rotating at High Speed
- Impact on Power Quality
- Feasibility of Relatively Unattended Operation
- Ability to Realistically Track Environmental Performance
- Dominance of Gaseous Fuel Option
- Use of Advanced, High-Temperature Materials

World Energy Engineering Congress 2000

Microturbine Business Developments

- Manufacturers setting up distributor and maintenance networks
- Market is growing slower than manufacturers' original estimates
- Energy companies developing unregulated DG subsidiaries
- DOE awards \$40M to six manufacturers

World Energy Engineering Congress 2000

Manufacturers Setting up Distributor and Maintenance Networks

- Honeywell - exclusive distribution territories mostly through RetailCos
- Capstone - non-exclusive distribution territories with RetailCos, reciprocating engine distributors, HVAC firms, ESCOs

Market is Growing Slower than Manufacturers' Original Estimates

- Most microturbines currently installed as “trial runs” or test programs
- Some manufacturers originally projected substantial market penetration in 1999-2000
- Increased volume could lower capital cost significantly (current costs are well above original estimates)

World Energy Engineering Congress 2000

Energy Companies Developing Unregulated DG Subsidiaries

- Many electric and gas utilities are developing unregulated DG subsidiaries
 - CP&L
 - New Energy Ventures
 - DTE
 - PECO
 - PSNM
 - Many others
- Utilities are also investing in equipment manufacturers

DOE Awards \$40M to Six Manufacturers

- Capstone - achieve efficiency, emissions, and cost objectives
 - GE - leverage on large-scale turbine technologies
 - Honeywell - critical components
 - NREC - industrial cogeneration
 - Solar - recuperators
 - United Technologies - increase performance and reduce costs for utility applications
-

World Energy Engineering Congress 2000

The Bottom Line for Microturbines Today

- Deregulation and Increasing Reliability Concerns May Accelerate Interest
- Meeting Technology Challenges Still a Wild Card
- Need Other Applications (e.g., transportation) to Build Volume and Establish Service Infrastructure
- Need to Offer Light Duty/Heavy Duty Technology Options

World Energy Engineering Congress 2000

What Might the Future Hold?

- A Proliferation of DG Installations, Driven by Power Marketers and Wires Companies
 - Very Small Point Emission Sources Essentially Escaping Regulation -- And Then Re-Regulation!
 - Material and Design Advances Enhancing Performance
 - Standardization of Design and Maintenance Practices (including Interconnection)
 - Gradual User Acceptance of DG as a Power Supply Option
-

World Energy Engineering Congress 2000